

Assembly Manual

In-circuit LOPT/FBT Tester

by Bob Parker

Cat No. **K 7205**

DICK SMITH
ELECTRONICS
ACN 000 908 716

K I T

PROJECT INFORMATION SUPPLIED BY
ELECTRONICS AUSTRALIA - August 1998 Issue



WEBSITE: www.electronicsaustralia.com.au
E-MAIL: electaus@magna.com.au

Please read Disclaimer carefully as we can only guarantee parts and not the labour content you provide.

Here's the design for a low cost, easy to build and use battery operated 'shorted turns' tester for line-output or 'flyback' transformers, and other HF wound components like deflection yoke windings and SMPS transformers. Tests have shown it capable of finding at least 80% of LOPT/FBT faults, so it can save a lot of time and trouble. Small and rugged, it's well worth a place in the toolkit of anyone involved in servicing TV receivers, video monitors and computer power supplies.

If you're reading this, then chances are that you're a TV and/or computer monitor repair technician - who doesn't need to be told that horizontal output stage faults cause more than their fair share of headaches! Operating at high voltages, frequencies and power levels, many components in this part of the circuit are highly stressed, and failures are not only common but their cause is often hard to identify.

The usual symptom of a major horizontal output stage fault is a serious overload of the DC power supply feeding the primary winding of the line output transformer, or 'LOPT' for short (called the 'flyback' transformer or 'FBT' in North America). This is often accompanied by a collector-to-emitter short circuit in the horizontal output transistor or 'HOT'.

(For consistency, we'll be referring to the line output transformer as the 'LOPT' throughout this article - North American readers please mentally substitute 'flyback' for this term!)

Any of quite a few possible components could be the cause of such a failure, the more common being one of the high-speed rectifier diodes fed by the LOPT's secondary windings, including the diode stack(s) which produce the extra-high-

tension (EHT) supply of around 25 kilovolts for the final anode circuit of the cathode ray tube. It's also possible the HOT has failed simply from old age or overheating due to unevenly-applied/solidified heatsink compound. Another occasional culprit is an insulation breakdown in the deflection yoke's horizontal winding.

However the failure which service technicians dread is a shorted winding in the LOPT itself. Unfortunately LOPTs tend to be specifically designed for the make and model of the TV or monitor they are used in, which can mean a lot of hunting around for a replacement. In addition they are hardly ever cheap, and not always physically easy to replace.

In short the LOPT is not a component which is easy to test by substitution, and a service technician needs to be as certain as possible that the LOPT really is defective, before tracking down a replacement!

Identifying faults

Several techniques have been developed over the years for identifying faults in horizontal output stages, and testing LOPTs in particular for the presence of shorted winding turns.

The components in the horizontal output transistor's collector circuit, including the LOPT's primary winding, deflection yoke horizontal winding, and tuning capacitors form a reasonably low loss (high Q) resonant circuit, especially at low voltage levels.

Most testing techniques, including the one used in this design, are based on the fact that nearly all serious faults in the



horizontal output stage will greatly increase the losses in the LOPT's primary circuit. That is, they lower the Q.

We chose the principle of 'ring' testing as the basis for this instrument because it's easy to implement with relatively simple circuitry and common components, and produces predictable results with no need for calibration.

'Ring' testing gets its name from the fact that when a fast pulse is applied to the primary winding of the LOPT, the total inductance and capacitance in the circuit will produce an electrical 'ring' - a decaying AC voltage which can have a duration of a dozen or more cycles before it reaches a low value. It's the electrical equivalent of tapping an empty glass; in each case, an energy impulse generates damped oscillations.

Waveform 'A' in Fig.1 shows the HOT collector voltage waveform in a typical fault-free TV (a General Electric TC63L1 in this case), in response to a pulse from this tester. However if the losses in the horizontal output circuit are increased, the amplitude of the 'ringing' waveform will decay much more quickly. Waveform 'B' shows the effect of a shorted rectifier diode on one LOPT secondary winding of the same TV, but note that a shorted LOPT winding or several other faults would have a similar effect.

A collector-emitter short in the HOT or a shorted tuning capacitor will result in no ringing at all, indicating a really major fault.

So to do an initial check of a horizontal output stage, with this tester, you first make sure the TV or monitor is de-energised(!). Then you simply switch the tester on, connect the ground lead to the

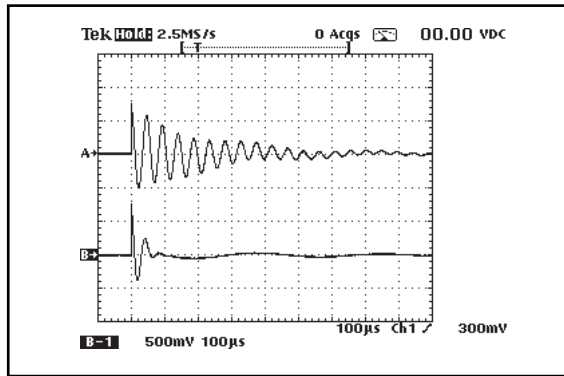

Fig.1: Ringing waveforms from 'good' (top) and 'shorted winding' line output transformers, in response to the tester's pulse.

chassis and the 'HOT Collector' lead to the horizontal output transistor's collector. One LED will illuminate for each 'ring' cycle above about 15% of the initial pulse value, and in general if four or more LEDs are glowing, the horizontal output stage is OK.

We'll talk more about using the tester later, after the circuit description. For the moment though, it's worth mentioning that because the tester uses a low-voltage testing pulse, it is suitable for testing LOPTs 'in circuit' - i.e., without having to disconnect the yoke or other connections.

Circuit description

At first glance the circuit in Fig.2 might look a bit complicated, but it really consists of three quite simple sections. These are the low frequency pulse generator, the ring amplitude comparator and the LED bar-graph display. We'll now look at these in turn.

1. The low frequency pulse generator: Voltage comparator IC1a is set up as a low frequency oscillator, whose output on pin 7 is normally pulled up to essentially the positive supply rail by R6 and R7. Due to the time constants produced

by C2, R4 and R5/D1, pin 7 pulses down to ground potential for about 2ms every 100ms, and it's during these low-going 2ms pulses that each ring test occurs.

When IC1 pin 7 drops low, Q1 is driven into saturation by its base current flowing in R7, and its collector voltage jumps to the +6V supply, which makes two things happen. First, C6 in collaboration with R16 sends a positive pulse of about 5µs duration to the reset pins of four-bit shift registers IC2a and IC2b, which drives all their outputs to a low state - switching off all the LEDs, in readiness for a new ring test.

At the same time, about 20mA flows through R8, driving D2 into a low impedance state and dropping about 650mV across it. The voltage step across D2 is coupled via C3 to the test leads and the LOPT primary winding, causing this circuit to 'ring' a bit below its natural resonant frequency due to the presence of C3 (which functions as the resonating capacitor when testing an LOPT on its own).

2. The ring amplitude comparator: The 'ringing' waveform is coupled by C4 to the inverting input of comparator IC1b, which is DC biased to about +490mV by the junction of R11 and R12. D3 is constantly forward-biased by about 1mA flowing through R10, and its entire voltage drop of about 600mV is applied to IC1b's non-inverting input as a reference voltage, via R13. R14 produces a small amount of positive feedback around IC1b, ensuring that its output switches cleanly between its low and high voltage levels.

The result of all this is that an inverted and squared-up version of the ringing waveform appears at the output of IC1b,

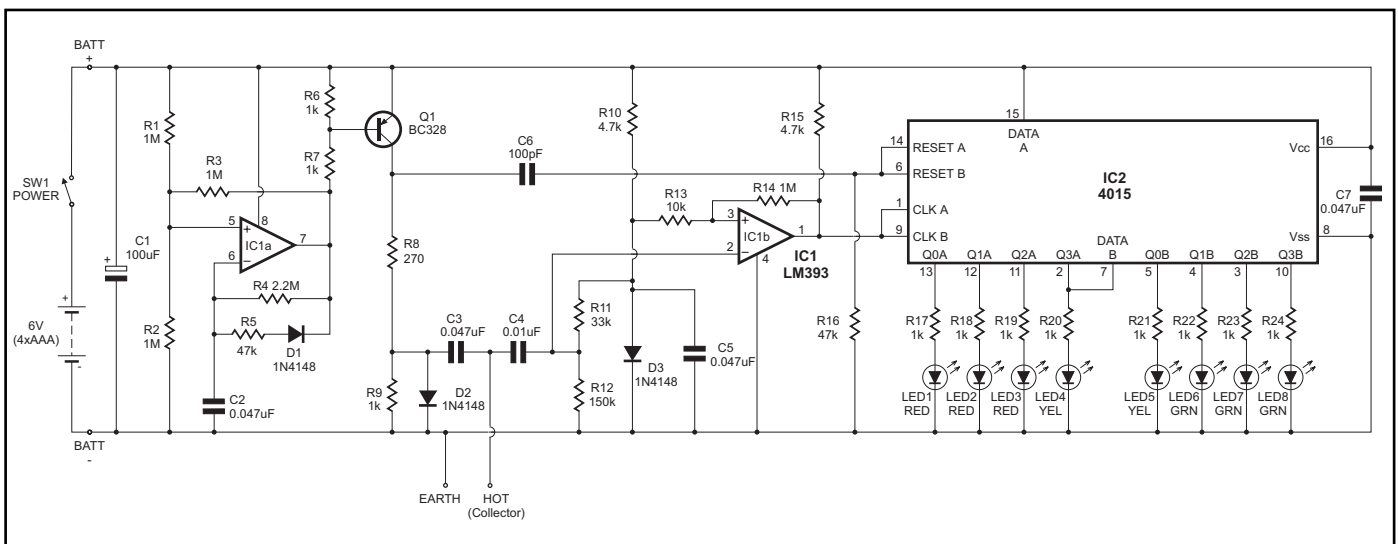

Fig.2: The circuit is simple, but elegant. IC2 shows clearly how many rings are supported by the inductor under test.

until the ringing amplitude has decayed down to about 15% of its initial value. This square wave is connected straight to the clock inputs of shift registers IC2a and IC2b.

3. The LED bargraph display: IC2 consists of a pair of identical four-bit serial-in/parallel-out shift registers, connected to form a single eight-bit unit, with each output driving one LED in the 'bargraph' display via resistors R17 to R24. The serial data input of the first stage (pin 15) is permanently connected to the positive supply, or logic 1.

One measurement

For the first 5µs after the commencement of a new 2ms measuring pulse, both shift registers are reset to zeroes on all outputs, as described earlier. At the same time the initial positive pulse applied to the LOPT drives IC1b's out-

put, connected to both shift registers' clock inputs, to a low (logic 0) level - unless the test leads are shorted.

If the LOPT primary circuit is OK, it will ring during the next several hundred microseconds. For each ring above about 15% of its initial value, it will cause a high-going pulse to be applied to the shift register clock inputs, resulting in the logic 1 on IC2 pin 15 being moved one shift register stage further along. It doesn't matter if the LOPT rings more than eight times - all LEDs will still remain illuminated.

So the overall result is that one LED illuminates for each LOPT ring cycle above 15% of the initial level, and this condition remains until the start of the next 2ms measuring pulse. Phew!

Usage & limitations

In order to assess the usefulness of this design, we gave several prototype LOPT/FBT testers to technician friends to evaluate for many months, then asked for their comments and thoughts on how to put the tester to best use.

The first response is from Larry Sabo, an experienced monitor technician in Ottawa, Canada who also suggested the front panel layout:

One of the first things I do to check out

a monitor is connect the tester between the HOT collector and ground. If no or only a few LEDs light, I check the HOT, damper diodes and tuning caps for shorts using a DMM. If these are OK, I check for an open fusible resistor in the circuit feeding B+ to the LOPT, and for shorts/leakage in diodes on the LOPT secondaries. I also check the bypass capacitor on the DC supply to the LOPT primary for excessive ESR.

If these check OK, I ring the horizontal yoke with its connector unplugged. It will normally ring seven times on its own. If the yoke rings OK, I unsolder all but the LOPT primary winding and ground pins, and ring the primary. If the primary still rings low with everything else disconnected, the LOPT is probably defective.

Most LOPTs on their own will ring 8+ times, but some ring only four or five, even when they are perfectly normal. So it is prudent to confirm the diagnosis by ringing an identical known-good LOPT, if at all possible.

Sometimes an LOPT is defective, but still rings normally with the tester, e.g. due to leakage or arcing that only occurs at full operating voltage. The problem will sometimes be manifest by heavy loading of the B+ supply, spurious ringing and/or reduced voltages on the HOT

Parts List

Resistors

(All 5% 0.25W carbon)

| | |
|-----------|----------|
| R1,2,3,14 | 1M |
| R4 | 2.2M |
| R5,16 | 47k |
| R6,7,9, | |
| R17-24 | 1k |
| R8 | 270 ohms |
| R10,15 | 4.7k |
| R11 | 33k |
| R12 | 150k |
| R13 | 10k |

Capacitors

| | |
|----------|----------------------------------|
| C1 | 100µF 16/25VW RB electrolytic |
| C2,3,5,7 | 0.047µF MKT |
| C4 | 0.01µF MKT |
| C6 | 100pF disc ceramic |

Semiconductors

| | |
|----------|---|
| D1,2,3 | 1N914 / 1N4148 silicon diode |
| IC1 | LM393 dual comparator |
| IC2 | 4015 / MC14015 / CD4015 dual 4-bit shift register |
| LED1,2,3 | Rectangular red LED |
| LED4,5 | Rectangular yellow LED |
| LED6,7,8 | Rectangular green LED |
| Q1 | BC328 / 2N5819 PNP silicon transistor |

Miscellaneous

PCB, ZA1137 51 x 76mm; small (UB3) plastic case, 130 x 68 x 41mm (DSE H-2853); front panel; battery holder for 4 x AAA cells; battery snap ; power switch, push on/off; one DIP8 IC socket, one DIP16; 4 x tapped spacers; screws, nuts and washers (see Screw size and allocation guide); 1 x red, 1 x black 4mm banana sockets; test leads with 4mm banana plugs; double-sided adhesive tape; wire, PCB pins, solder and instructions.

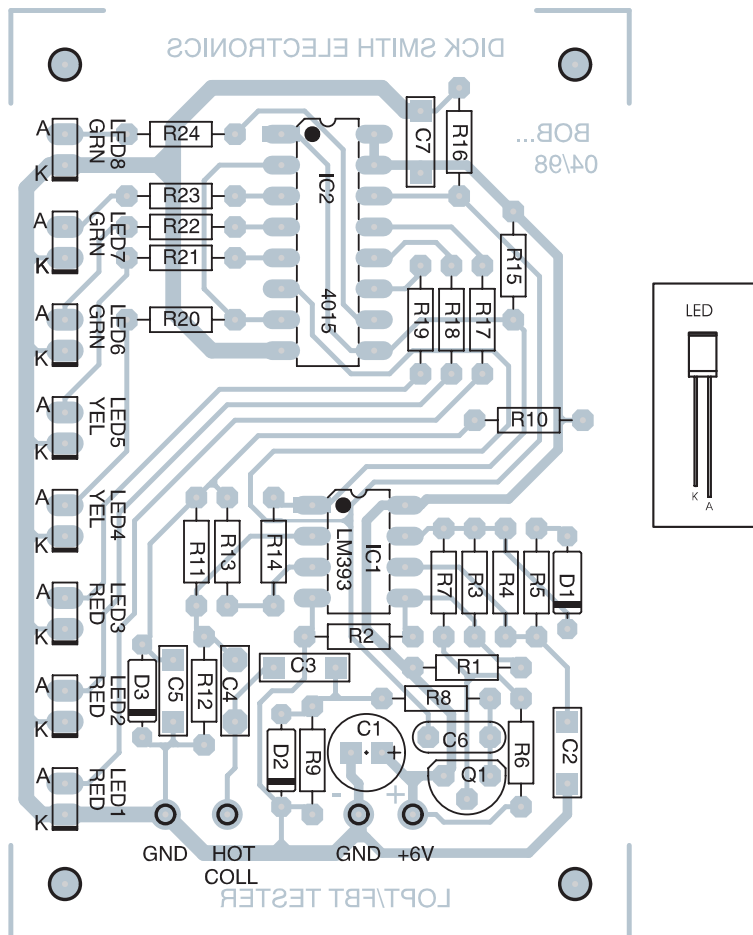

Fig.3: Use this PCB overlay and the facing photo as a guide in assembling the tester.

collector, or excessively high EHT resulting in HV shut-down.

Because this tester uses impulses of only 650mV to minimize the forward biasing of semiconductors, such defects will not be reflected in the ring count. Under these circumstances, I check for measurable leakage resistance between the EHT cap and the other LOPT pins. It should be unmeasurable, otherwise the LOPT is defective.

If I have gone through the above tests and have these symptoms and a normal ring count on the tester, the diagnosis can usually be confirmed only by substituting a known-good identical LOPT, or by testing with a chopper similar to the one described in Sam Goldwasser's Electronics Repair FAQ, located on the Internet at <http://pacwest.net/byron13/sam/flytest.htm>.

Something else I do when testing a LOPT is to supply it with a reduced B+ to enable scoping the HOT and measuring EHT (in situations where the monitor goes into HV shutdown). To reduce the B+, I use two light bulbs in series, one end to B+ supply, centre-tap to LOPT B+ connection, other end to ground. One bulb is 60 watts, the other is 100, so I can reverse the end leads and increase or decrease the B+ value used in testing.

At the outset, when I have power supply cycling but have confirmed there are no shorts from HOT-C to ground, I substitute a dummy load (60W bulb) for the LOPT where the B+ enters, to see if the power supply works with the LOPT out of the equation.

Screw Size and Allocation Guide

Printed Circuit Board to Spacers
4 x Screw M3 x 6mm (zinc plated)

Front Panel to Spacers
4 x Screw Countersunk M3 x 6mm (Blk)

Front Panel To Case
4 x Screw Countersunk No4 x 6mm (Blk)

Resistor Colour Codes

| Value | 4 Band (1%) | 5 Band (1%) |
|-------|-----------------|---------------------|
| 270R | Red-Vio-Brn-Brn | Red-Vio-Blk-Blk-Brn |
| 1K | Brn-Blk-Red-Brn | Brn-Blk-Blk-Brn-Brn |
| 4.7K | Yel-Vio-Red-Brn | Yel-Vio-Blk-Brn-Brn |
| 10K | Brn-Blk-Org-Brn | Brn-Blk-Blk-Red-Brn |
| 33K | Org-Org-Org-Brn | Org-Org-Blk-Red-Brn |
| 47K | Yel-Vio-Org-Brn | Yel-Vio-Blk-Red-Brn |
| 150K | Brn-Grn-Yel-Brn | Brn-Grn-Blk-Org-Brn |
| 1M | Brn-Blk-Grn-Brn | Brn-Blk-Blk-Yel-Brn |
| 2.2M | Red-Red-Grn-Brn | Red-Red-Blk-Yel-Brn |

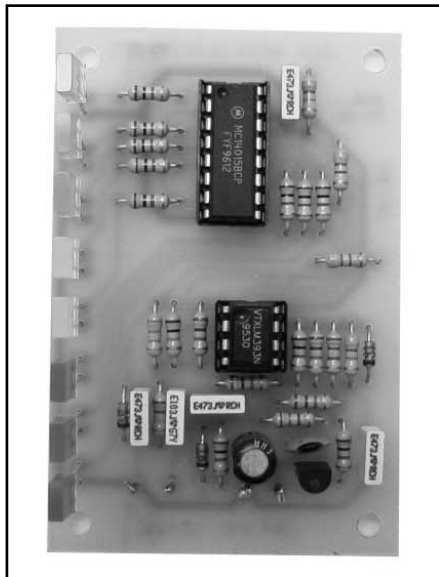

The assembled PCB, which supports virtually all of the circuitry.

Overall, the LOPT tester can identify about 80% of LOPT failures. When trying to solve a puzzle, if someone offers information that is right 80% of the time, it's a lot better than having to guess 100% of the time, especially if the ante is the price of a LOPT and wasted, valuable time.

Michael Caplan does general electronic servicing in Ottawa, and added the following useful points in relation to TVs:

It's pretty straightforward to use, with the usual precautions of ensuring that the under-test unit power is off and any caps are discharged.

When testing an LOPT in circuit, it might be necessary to disconnect some of the LOPT terminals, and/or yoke plugs that could load it down and upset the readings. The tester will often not detect bad HV diodes in integrated split-diode LOPT units, nor shorts/arcing that is voltage dependent - but then no other passive tester does either.

I have found it useful for checking TV deflection yokes, both horizontal and vertical. A good yoke lights at least five and typically the full eight LEDs. However, many yokes have built-in parallel or series damping resistors, and

these must be temporarily disconnected. Otherwise the reading will be low, even though the winding itself is fine.

The tester can be used for checking high-Q transformers such as those used in SMPS's. However, my experience has shown that it will not provide more than a two or three LED indication for good TV horizontal drive transformers. It can be used for these, however - to indicate shorts (no LEDs lit). On the other hand the ESR Meter (Dick Smith catalog number K-7204) can do much the same with these low resistance transformers.

Wayne Scicluna services TVs in Sydney, and is the technician who talked me into developing the tester in the first place. Here are his hints:

If you've already checked for the more obvious leaky and shorted semiconductors and capacitors etc., and are still getting a low reading on the tester, there are some other traps to avoid.

You need to get a good connection with the test leads, because contact resistance can cause a low reading. The same applies to defective solder joints in the horizontal output stage, especially on the LOPT itself and HOT. In fact connecting the tester with clip leads, flexing the board and wiggling components is a good way to show up bad solder joints in this area.

Body conductivity can also cause a lower than normal reading if you're touching the test leads and your skin is damp. Low readings can also be caused by having the test leads reversed, i.e., connecting 'HOT Collector' to chassis, and by faults in an external voltage tripler.

How to build it

Before soldering anything to the printed circuit board, hold it up to a bright light and examine the copper side carefully for fine track breaks and especially whiskers or bridges - particularly where tracks pass close to component solder pads.

Referring to the board overlay in Fig.3, begin installing the components, starting with the resistors and diodes and working your way up to the tall ones including the four PCB pins for 'GND', 'HOT' and '+6V' terminal connections- but leaving

Capacitor Codes

| Value | IEC Code | EIA Code |
|---------|----------|----------|
| 100pF | 100p | 101K |
| 0.01uF | 10n | 103K |
| 0.047uF | 47n | 473K |

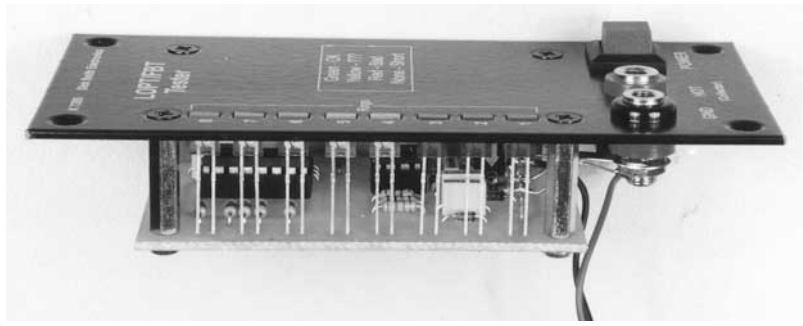
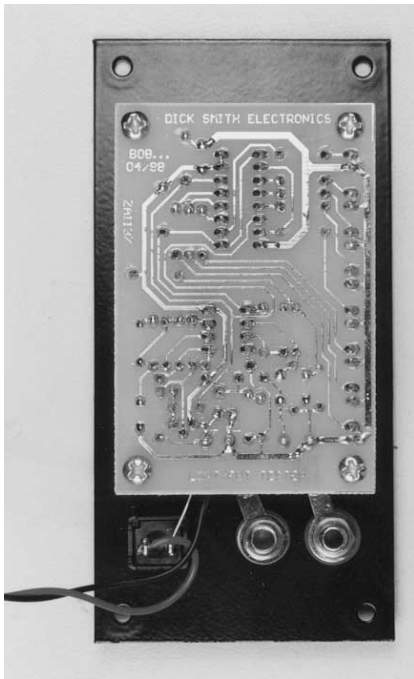

the LEDs off the board for now. Take care with the orientation of the polarised components, including the IC sockets.

With everything but the LEDs installed on the PCB, once again illuminate it from the top, and check for and correct any solder bridges or other problems.

Now turn your attention to the front panel, mounting the banana sockets and the power switch in their respective holes.

Attach the tapped spacers to the corners of the board using plain 3mm screws, and solder long component lead offcuts to the 'GND', 'HOT Collector' and '+' solder pads, followed by the battery snap's black wire to the '-' pad. Then, without soldering them, poke the leads of all the LEDs through their respective holes in the board. Make sure the coloured LEDs are in their correct places, and that all the (long) anode and (short) cathode leads are correctly oriented as shown in Fig.3.

Using black countersunk 3mm screws, attach the front panel to the board assembly and place the whole thing face-down on a soft flat surface. Manoeuvre all of the LEDs into their cutouts in the front panel, and push each LED down slightly to ensure its face is level with the front of the panel. In the unlikely event that a LED won't fit, use a small file or similar to remove the excess powder coating inside the hole.

Now solder all the LEDs into place, then connect the test lead sockets and the closest terminal of the power switch to their respective wires from the board, and finally the red battery snap wire to the free switch contact (Ref. to Fig.4.

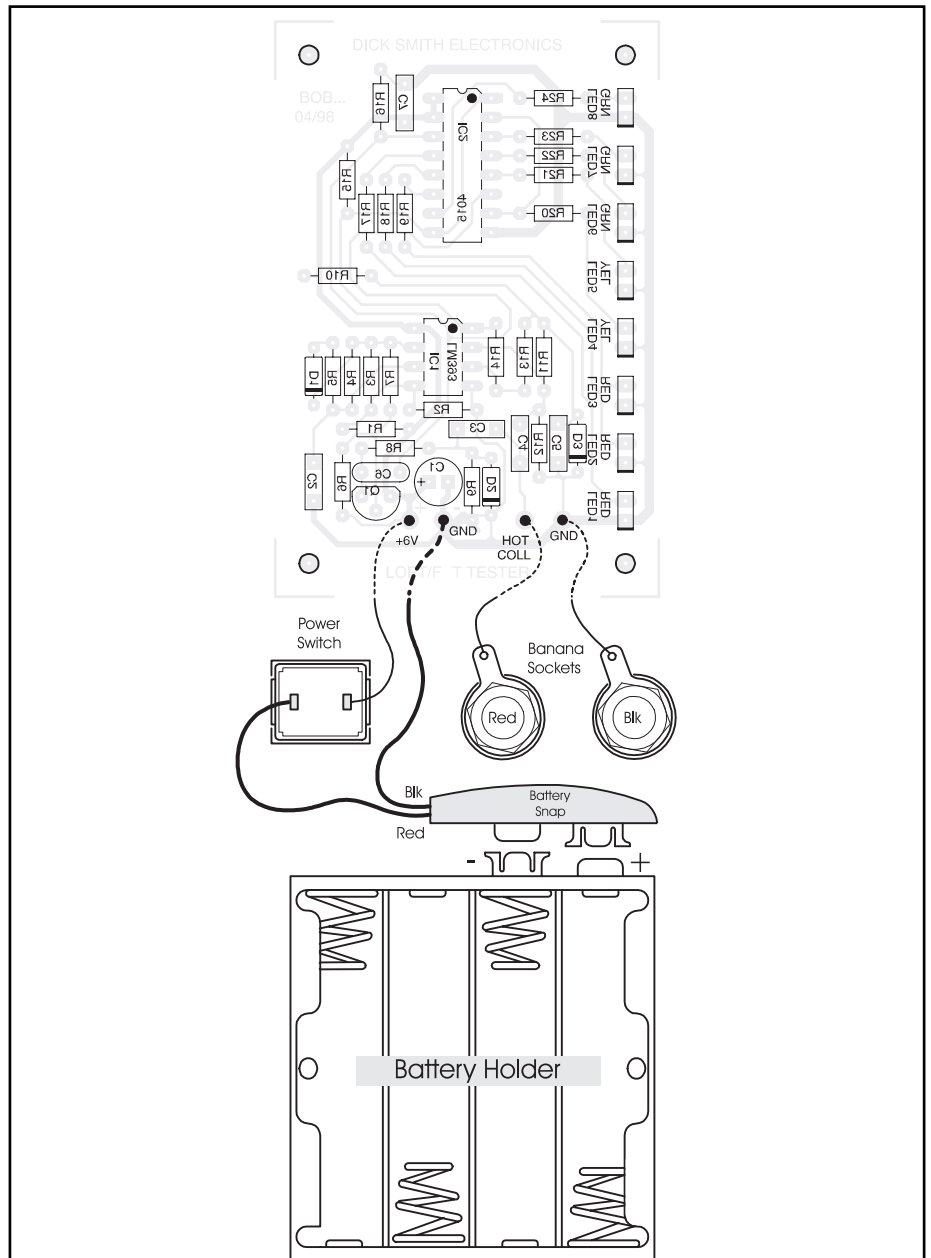

Fig.4: Shows how the battery snap (positive lead) is wired through the switch to the printed circuit board. Note, as the component overlay shown is viewed from the copper side of the PCB, wiring terminations for the Power and Hot Collector/GND should be made to the PCB pins on the component side of the board.

wiring diagram).

Snip off the battery holder's PCB mounting pins, then install four 'AAA' cells into it. Connect the battery snap to the terminals, and switch the unit on. If everything's OK then the bottom red ('1') LED will illuminate, and shorting the test leads will cause it to go off.

An effective way to test the unit is to

connect the test leads to the primary winding of a known good LOPT out of circuit, which should bring all eight LEDs on. Then thread a loop of solder around the ferrite core of the LOPT (simulating a single shorted turn), and the LED count should drop to 1-3 as the loop is closed.

If everything's OK, use double-sided

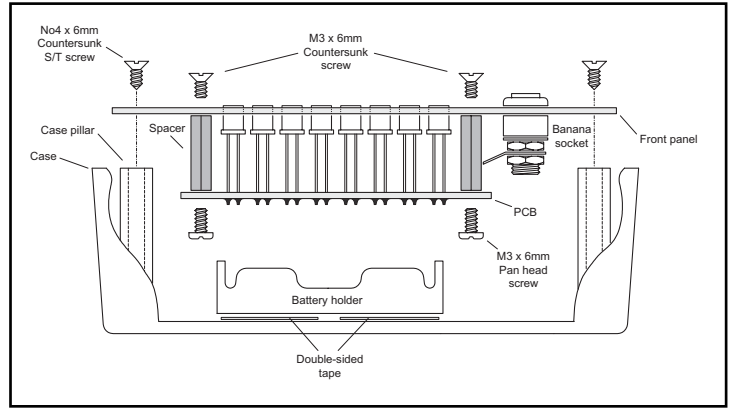
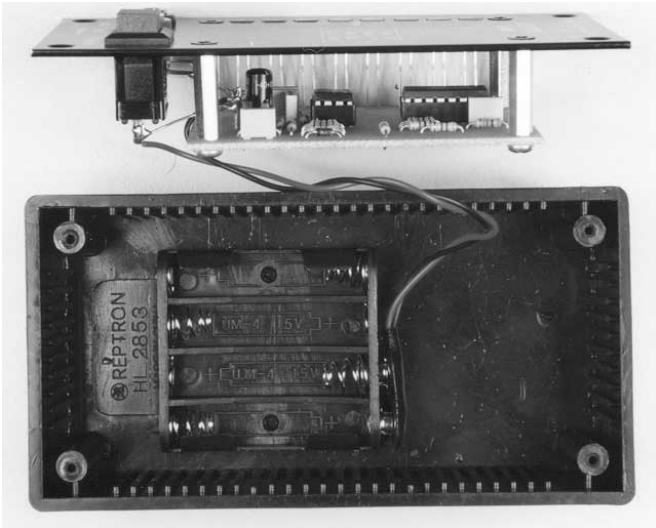

Fig.5: Shows how the PCB with LEDs is mounted to the front panel using 19mm hex tapped spacers. The battery holder is fixed to the bottom of the case by two pieces of double-sized tape.

adhesive tape to stick the battery holder into the bottom of the case, with the cells aligned in a 'north-south' direction for easiest access. All that remains to be

done now is to screw the front panel into place and try out your tester on some LOPTs and their associated circuitry.

Finally, our sincere thanks to Larry

Sabo, Michael Caplan and Wayne Scicluna for their assistance in completing this project. We couldn't have done it without you!

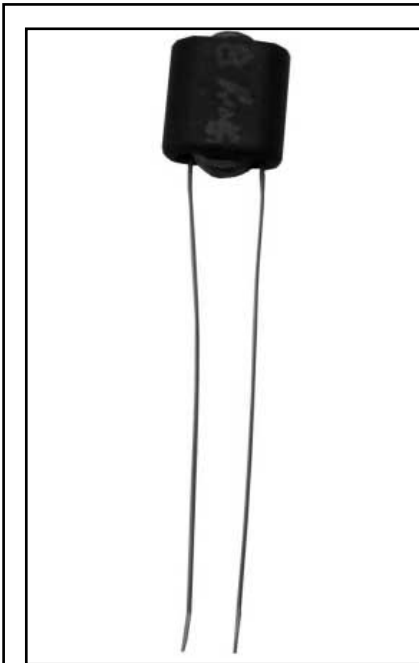

Winding a Test Coil

In order for constructors to test the unit once assembled we have provided details and parts to construct a simple transformer coil which enables the circuit to ring all '8' LEDs.

Please refer to the following for coil details.

1. Using the balun core provided, wind around 45 turns (tightly wound) through the two centre holes as shown in the accompanied photo.
2. Once completed trim lead length to approximately 50mm and clean the enamel from each lead end so that a positive connection can be made.
3. Now test the coil, the unit should display and ring all '8' LEDs. By simply feeding through an additional winding and shorting the ends will reduce the rings to either 1 or 2 LEDs giving a good indication that the unit is working correctly.

Parts Supplied

- 1 x Balun core (R 5440)
- 1 x Enamel copper wire (30B&S or 0.25mm dia x 2 metres)

Assembly Notes



ACN 000 908 716

CNR Lane Cove & Waterloo Roads
North Ryde NSW 2113

PH: (02) (Int 612) 9937 3200 Fax: (02) 9888 3631